

# **Introducing SHUR KUT Engine Mounted Radiators**



**Suitable for :-  
DG Sets Working on Diesel & Gas.  
Any Make Any Size.**

## About us

Shur Kut is engaged in designing, manufacturing of finned surface air cooled heat exchanger in India. Our years of experience, in depth knowledge of the product application has lead us master in our field. Today we are proud to be a part of being a part of the fast growing Indian economy.

Over years our managing director Mr. Jagjit Singh had been working in the field of heat transfer. With his sound background of heat transfer & having work experience in some of the American companies have made him a leader in the designing & manufacturing. With nearly twenty five years of experience in the industry of heat transfer specially in finned surface heat exchanger has led him a positive thinker, go getter & quick decision maker.

As per him “ We are Shur Kut are of a believe that it is our moral duty to supply quality product to our esteem customers who trusts us for their requirements for the finned surface equipment.”

Our company has specialized in the large engine cooling systems. We have done nearly 400 MW projects in the past few years. Now we are proud to introduce engine mounted radiators. This is with the unique technology of round copper tubes & plate type aluminum fins. We have tried to consolidate the design features as well as different combinations in this brochure we sincerely hope that it will be welcome by the industry.

## Our Manufacturing & Testing facility

Our manufacturing facility is located at IMT Manesar that is about 30 Kms. from the New Delhi International Airport. We have around 20000 Sq.feet of area. The following machines are installed in house :-

A) Fin Punching Line :- A complete fin punching line to punch the fins. The high speed press is of Schuller- German & Fin punching die is from Burr Oak - USA. The combination of the same makes it a quality & reliable source of fins.

B) CNC Turret Punch Press :- The tube sheets are processed on the CNC Turret punch press. The accurate & high speed punch press is of Titan make- Belgium.

c) Tube straighting & Cut Off line :- The tube starighting & cut off line is from Burr Oak - USA. These is a high speed line that cut tube at the speed of .....

d) Tube Expansion :- Quality tube expansion equipment ensures accurate bounding which ultimate decides the heat transfer factor.

e) Sheet metal processing Machines :- We are fully equipped with sheet metal processing line. We have in house sheet cutting machines, bending machines, nibbling machines, Tube rolling machines & MIG & TIG Welding Machines.

f) Testing Facility :- All the radiators leak tested & if it is external fan driven motors these are run to test for air volume, noise & vibration.



## Design Features

Shur Kut range of engine mounted radiators have many features when compared to conventional type of radiators. Some of the design features are as under :-

a) Fins :- Shur Kut Radiators consists of fins that are made up aluminum. These fins are punched on a progressive die. The fins have features :-

i) Surface :- The surface of the fins is corrugated. It means that the air when passing over the fins gets maximum turbulence . It means that the air will get more time to exchange the heat.

ii) Staggered tube pattern :- The tubes are placed in the staggered pattern instead of in line. The air moves in the specific pattern taking the heat out of radiator.

iii) Fully drawn collar :- This means a maximum contact area with the fins.

iv) Reflared collar :- This maintains the fin pitch to have the uniform air velocity over the radiator.

v) Rows deep :- The fins are punched according to the set program. The rows deep can vary from single row to twelve rows.



**Fins have corrugated Surface for maximum turbulence of air around the tube.**



**Full drawn , Reflared & Nested Collar of fin ensures maximum contact between fin & tube.**

**Constant gap in between the fins ensures uniform air flow.**



**Fins are punched on Burr Oak , USA die . This is the best die available in today's world.**

## Design Features of Engine Mounted Radiators



**Fins :-** Normally of aluminum, but we can also provide the fins for copper, Cupro nickel or brass for different environments .

**Tubes :-** Standard radiators are manufactured out of copper tubes. We can also offer the tubes in Aluminum, brass or steel tubes.

**Fin to Tube Contact :-** The tubes are mechanically expanded into the fins. This is done by passing tungsten carbide tips in full length of the tube. This ensures maximum contact in between the fin & tubes. While expanded the tubes the tubes become hard because of the mechanical work done. This gives the extra strength to the tubes which helps the fin tube block to withstand the higher air velocity as well as the vibrations.

**Headers :-** Fabricated out of steel, punched on CNC Turret punch press & bend on hydraulic press. The headers are complete with the radiator filling caps, Inlet & outlet connections.

**Tube to tube sheet joints :-** Tube sheets are manufactured out of copper sheet for copper tubes. The holes of tube sheet are drawn to nearly equal size of the diameter of tube. Then each tube is manually brazed to form a solid contact between the tube & tube sheets.

**Fan Cowl :-** Fan cowls are fabricated out of steel & are given good number of stiffeners to withstand higher air velocity. We take care that at a higher air velocity the fan cowl should not sag or get wrapped up.

**Fan Suction Grills :-** The fan suction grills are designed in such a way that when fan runs it should not vibrate.

**Front Core Protection Grill :-** Every Radiator comes with the front protection grills. These grills are strong enough to protect the fins.

**Radiator Mountings :-** Radiators are mounted on the steel plates. These plates have pre holes so that this can be directly mounted on the base frame of the engine.

**Lifting Hooks :-** All the radiators are supplied with two numbers of lifting hooks on the top. These can be lifted with the help of wire ropes.

**Testing :-** All the radiators are tested two times the working pressure before shipment.

**Paints :-** We offer different type of wet & dry paints as per your engine color & paint.



## How Shur Kut Radiators are different from conventional Radiators?

### FINS :-

Conventional Radiators have the corrugated fins with Zig Zag Pattern. These fins are vacuum brazed in the furnace. The contact area on these fins is very less.



Fins of Shur Kut radiators is of plate type having corrugated surface for the maximum turbulence in the air. This makes our radiators more efficient than the conventional radiators.

### Tubes :-

Tubes of conventional radiators are square. Due to the construction of such tubes gets choke very fast. Once somebody uses normal water the salt is generated & it chokes the tubes quickly. The salt cannot pass thru the tubes. Thus the radiator becomes inefficient.



Tubes of Shur Kut Radiators are round have also less pressure drop on liquid side when compared to the conventional radiators. The tubes can be easily cleaned for maintains.

Tubes of Conventional Radiators

Tubes of Shur Kut Radiators



Normally conventional type of radiators are manufactured in two portions. in height. Whereas Shur Kut radiators comes in a single piece i.e., there will be no joint in between the core. Therefore less leakage chances.

Fin to tube contact :- In the conventional radiators the fins are normally soldered to the tube. This makes the radiator not only bulky & also inefficient. Shur Kut radiators tubes are expanded either mechanically or hydraulically. This forms an excellent contact between the tubes & fins which ultimately creates a good heat transfer media.

## Radiators with external driven fan & Motor

Shur Kut Engine mounted radiators with external driven fan & motor is meant for the area where engine mounted fans are not available. The typical application is change of the cooling system from one system to another. For example if the genset has been running on the cooling tower & it is to be replaced with the engine mounted radiator . In such case no engine driven fans are not mounted, at these places the radiator with external driven fan & motor are used. We have two readily available options in these type of radiators. One is with fan mounted direct on the motor. Second is fan driven by belts & pulley.



**Radiators with Fan Mounted Direct on Motor**



**Radiators with Fan Mounted on Pulley & shaft**

Benefits of External Driven Fan & Motor :-

There are number of benefits in external driven fan & motor. Some of the benefits are listed below :-

- a) These radiators are mounted with the fan that has variable angle blades. This means that the air volumn of these radiators can be changed at any time even at the site also.
- b) The fans are constructed out of either with PAG hubs or aluminum hubs. The blades can be of PAG, PPG or aluminum. This will all depend on the environmental conditions & what is required at site. We have complete flexibility for the same.
- c) All motors are 3 phase & of IP55 rating.
- d) The biggest advantage of these type of radiator is that the fan motor speed can vary with the load. This saves a lot on the engine power. The power saved from this can be utilized in the power generation.
- e) This type of system is very easy to maintain.

# Exploded View of Radiator

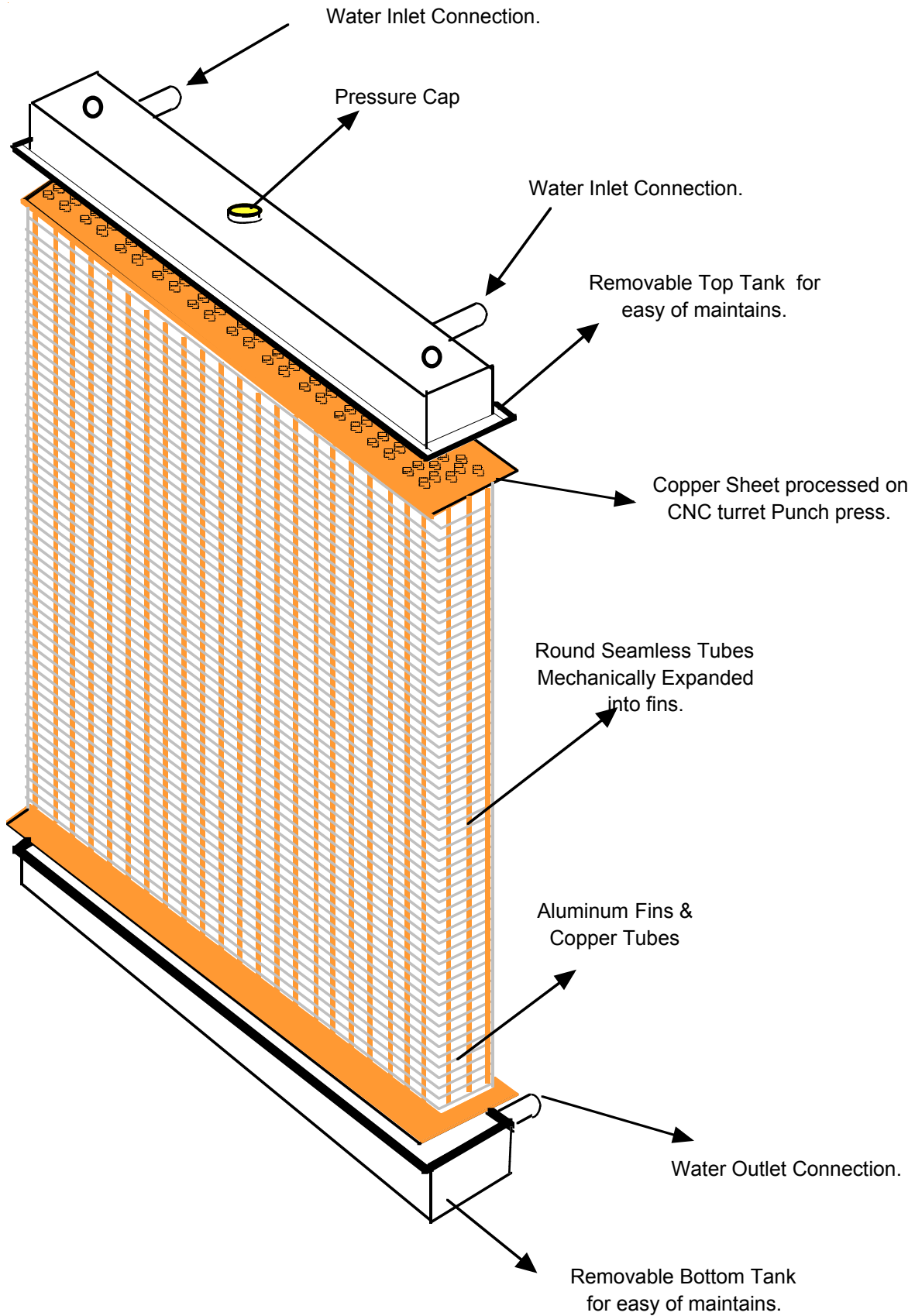

## **Radiator with Fuel Oil cooler.**

Shur Kut Engine mounted radiators with external driven fan & motor or without can be fixed with Fuel Oil Coolers. These coolers are fixed in between the radiator core & fan. These are constructed in such a way that these coolers can be slide in & out for maintains without disturbing the radiator assembly.



**Some of the design & Construction feature of fuel coolers are :-**

- \* Made out of aluminum fins & round copper tubes.**
- \* Every tube is expanded into fins to foam a firm contact between fins & tubes.**
- \* All fuel coolers are tested at 10 Kq/cm2.**
- \* Fuel coolers are designed in such a way that these can be slide in & out for maintains without distributing the rest of the mounting of radiator.**
- \* User friendly to run & maintain.**

## **Radiator with Fuel Oil cooler.**

Shur Kut Engine mounted radiators with external driven fan & motor or without can be fixed with Oil Coolers. These coolers are fixed in between the radiator in the front of the core. The design confirms a smooth running operation. Some of the design & construction feature includes :-

- a) Fuel Coolers are made up of aluminum fins.
- b) Tubing can be of aluminum or cooper.
- c) Slide in type design, means that the fuel oil cooler can be slide out from the camber at any time fro easy of maintains.
- d) In let & out let connection are hydraulic type,
- e) All the fuel oil coolers are tested at 21 Kg/cm2.

## Radiator Fans

Shur Kut radiators with external driven thru direct motor or mounted thru indirect motor has following advantages :-

All fans have variable angle for the ease of changing the air flow at any time.

- Normally the blades are made up of PAG material.
- These fans are light in weight & tough in construction.
- The light weight means less stress on the motor shaft.
- The fan comes with the multiple blades.
- Fans can be directly driven by motor or thru the shaft & Pulleys.
- Quick to change & easy to maintain design.
- Fans are available right from 600 MM to 1500 MM.

**Standard Radiator Dimensions from 40 KVA to 500 KVA.**  
 (Applicable of General Engines working on Diesel)

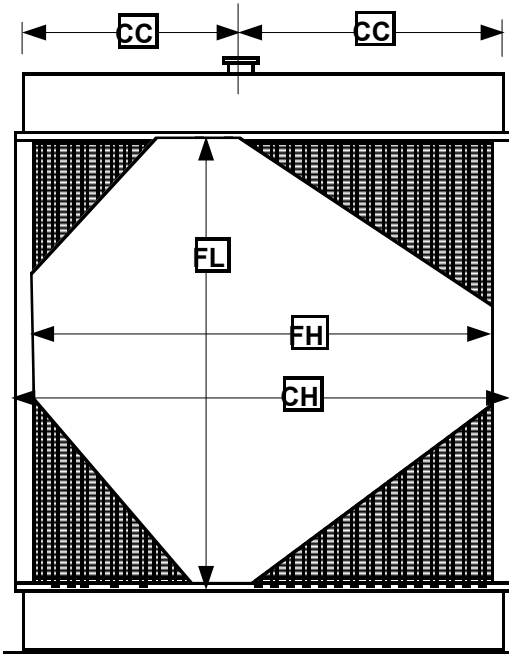

(Front View )

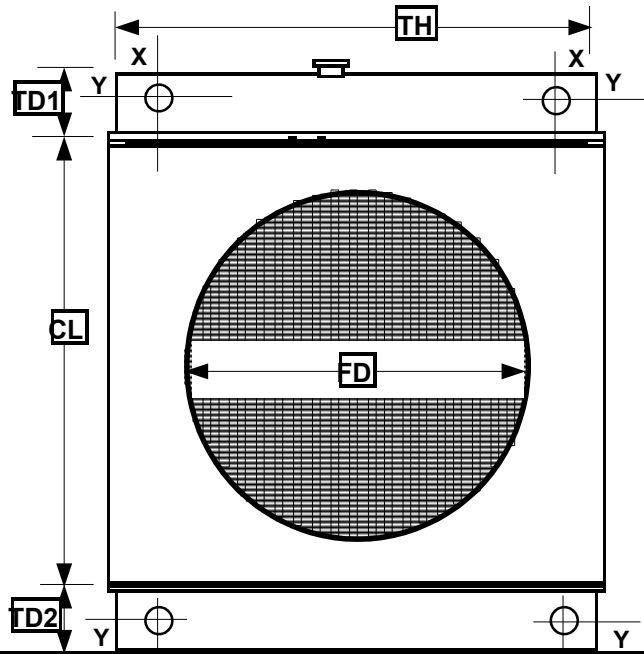

(Back View, fan & Connection Side )

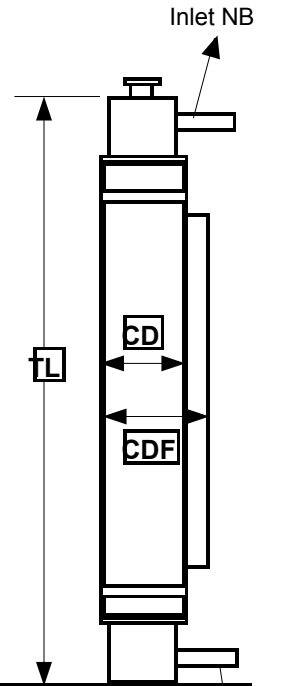

(Side View )

Outlet NB

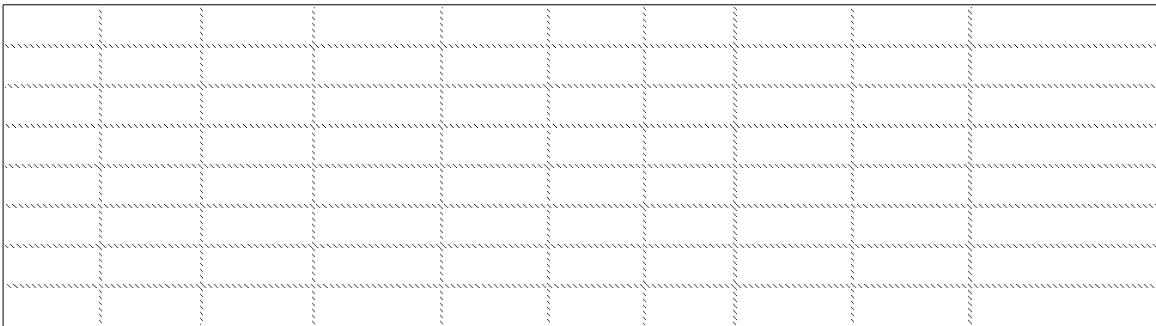

**Standard Radiator Dimensions from 600 KVA to 2000 KVA.**  
 (Applicable of General Engines working on Diesel)

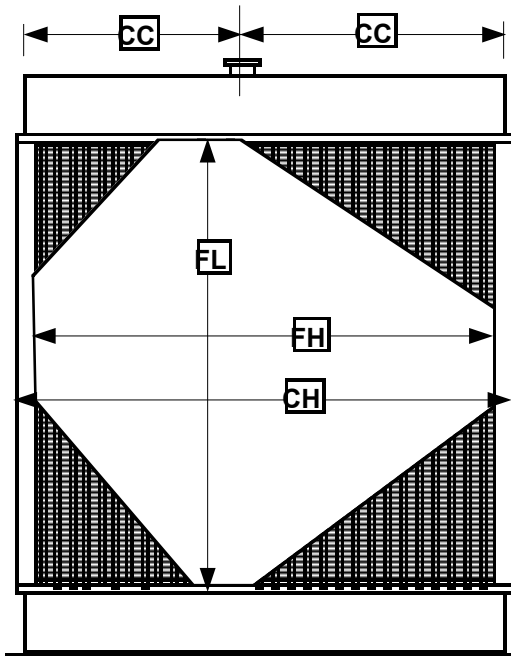

(Front View )

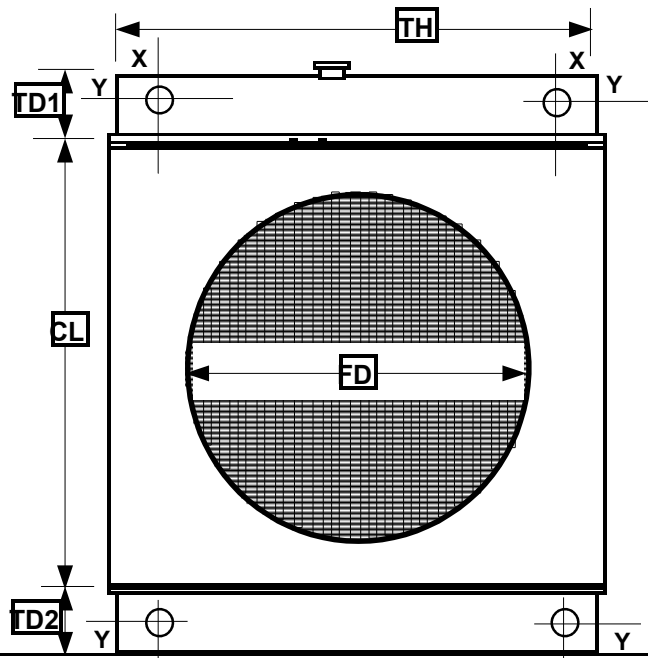

(Back View, fan & Connection Side )

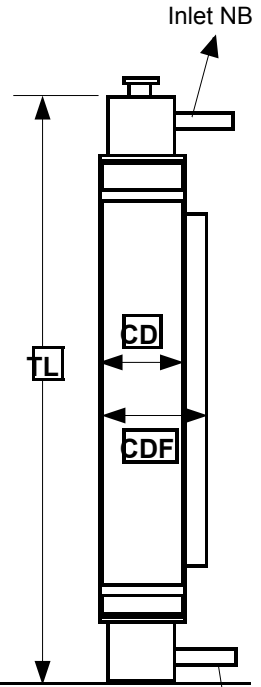

(Side View )

Outlet NB

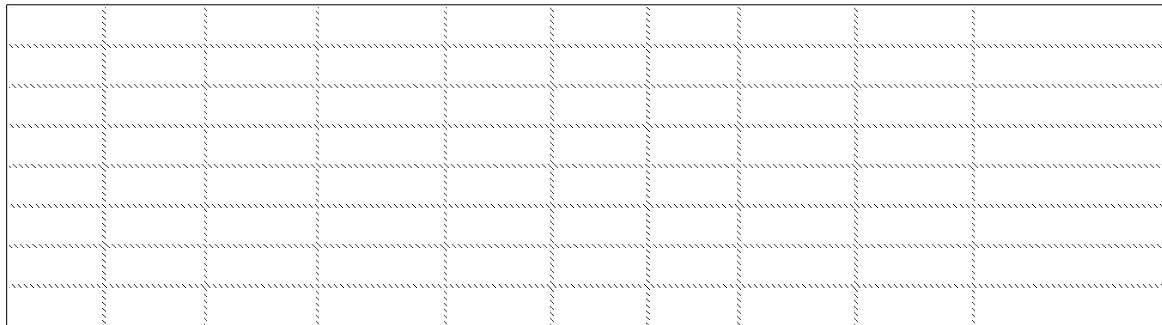

## ***Some of the other products of Shur Kut***



Dry Type Remote Radiators from 40 KVA to Any Mws.

Application Includes :-

Diesel DG Sets

HFO DG Sets

CNC Gas DG Sets

Natural Gas DG Sets.

Sewage Gas DG Sets



Air Cooled Oil Coolers

Application Includes Cooling of :-

Quenching Oil Coolers.

Hydraulic Oil Cooling.

Pressure Die Casting.

Large Motor Bearing Cooling.

Wire Drawing Oil Cooling.

Electrical Transformer cooling.

Autoclave Water Cooling.

*for more information please contact :-*

**Shur Kut Heat Transfers (P) Limited.**

Plot No. 77, Sector 6, IMT Manesar, Dist Gurgaon, Haryana.

Tele: 0124- 4367290, 91, 92, 93 & 94.

*Delhi Office :-*

C -16, Rajouri Garden, New Delhi - 110027, India

Telefax :- 011 41447267, e-mail :- shurkut@hotmail.com

web site :- [www.shurkutindia.com](http://www.shurkutindia.com)