



**S.V.A. Rikkon Lube Pvt. Ltd.**



The Rikkon Grease Injectors Model SVM 32 can dispense lubricant up to grease grade NLGI-1 and they can be manually adjusted to dispense a precise amount of lubricant as per actual bearing requirements.

They can be installed either individually at each bearing point or grouped manifold with feed line supplying lubricant to the bearing. They can be used in the system along with SVM 33 and SVM 1.

**Special features :**

- ◆ Output volume adjustment.
- ◆ Visual indicator pin
- ◆ External grease fitting.
- ◆ Easily interchangeable.





**Rikkon Lube Injectors  
Model SVM-32**

## SVM-32 Dimensional details

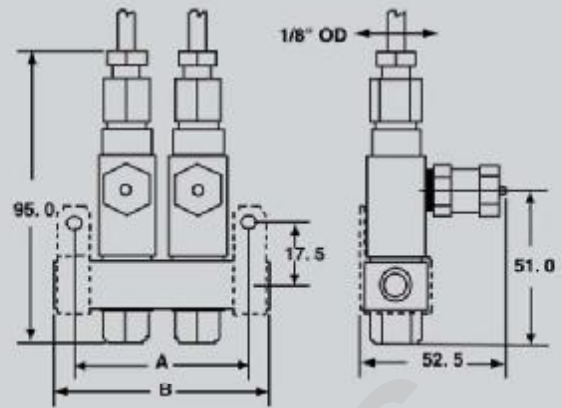
Model #	Description	Dim. "A" mm	Dim. "B" mm	Lubricant inlet
SVM 321	1 Way	30.0	45.0	1/4" NPTF
SVM 322	2 Way	50.0	65.0	1/4" NPTF
SVM 323	3 Way	70.0	85.0	1/4" NPTF
SVM 324	4 Way	90.0	105.0	1/4" NPTF
SVM 32U	unit assly	NA	NA	NA



-  Lubricant under pressure
-  Lubricant output

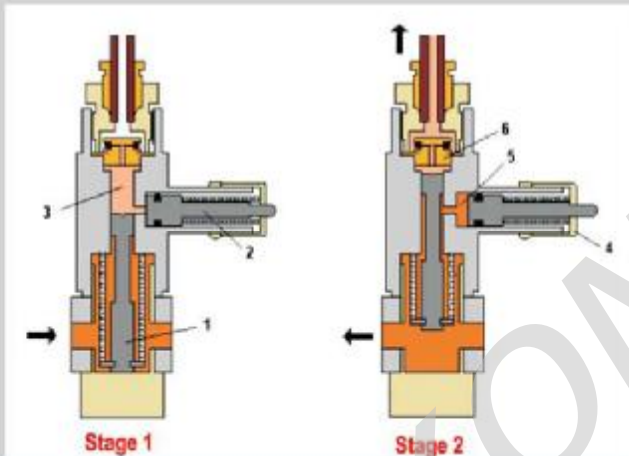

### Part details:

1. Plunger
2. Retainer
3. Discharge chamber
4. Capnut
5. Measuring chamber
6. Non-return valve

**Stage 1 (Supply line pressure):** Lubricant pressure moves the plunger which forces the lubricant in the discharge chamber through the outlet check valve to the feed line.

**Stage 2:** With the supply line getting vented, plunger returns to normal position, connecting measuring chamber to the discharge chamber. The outlet check valve blocks the flow from feed line, the lubricant is automatically transferred to discharge chamber from measuring chamber.

**Injector tuning:** The injector output is controlled by the position of the indicator cap which hunts the travel of the packing retainer. With the indicator cap hand tightened, the lubricant output is decreased to a minimum. Retracting the indicator cap two full turns permits maximum lubricant is to be dispersed. Beyond that the output will not increase even if the indicator cap is retracted.

After the injector is adjusted for the proper lubricant output, the lock nut is tightened.

## Technical specifications

Description	Specification
Output Lubricant Voume per cycle	Adjustable
Minimum	0.001 cu.in. (0.016 cc)
Maximum	0.008 cu.in (1.131 cc)
Operating Pressure	Minimum 1200 PSI (82 Bar)
Maximum	3500 PSI (241 Bar)
Recommended Operating Pressure	1500 PSI (102 Bar)
Reset Pressure	200 PSI (14 Bar)
Recommended Fluids	Grease NLGI Grade 1 or Lighter
Outlet port size	1/8" OD or 1/4" OD Tube Connector
No. of Outlets	upto 4 outlets

Office: A2-16 Aishwaryam Apts, 4th Main Road, Nolambur,  
Chennai - 600 095, India. E-mail: rikon@touchtelindia.net  
Tel: +91 98400 40083