

Valves/ Hand Shut off Valves

Application

These diaphragm type hand shut off valves are designed for installations in liquid, suction and hotgas lines of commercial refrigerating systems and on civil and industrial air-conditioning systems.

Construction

Diaphragm valves don't have gland seals. The external sealing is assured by thin metal discs (diaphragms), which hermetically divide the spindle chamber from the fluid flow area.

The main parts of the valves are made with the following materials

- hot forged brass body as per BS-218
- extruded brass for the spindle
- special spring steel for the spring
- engineering Plastics for seat sealing gaskets

Features

- can be used on all CFC's and HCFC's
- seat of Engineering Plastics to give complete shut off with minimum torque
- fitted with stainless steel diaphragms that prevent leakage throughout the operating life of the valve

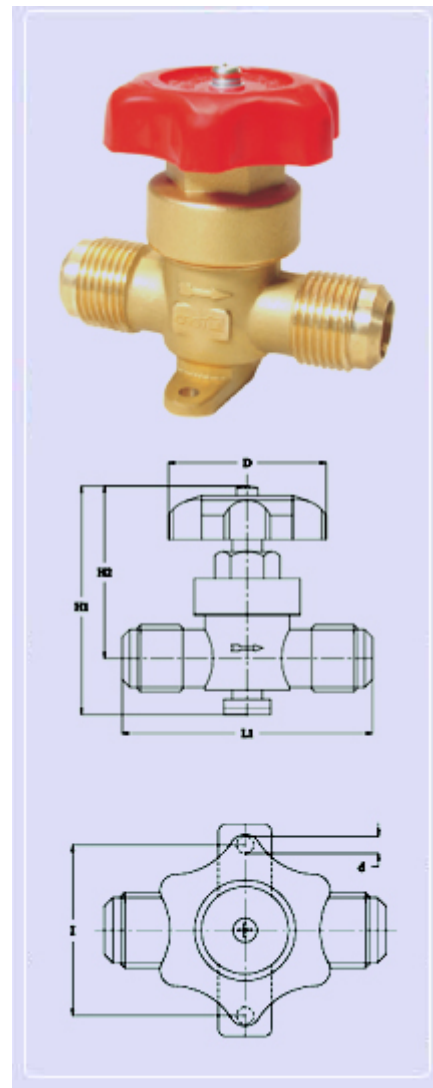

Model	Size Flare	Size OD	Operating Temp		Operating Pressure
			°C Min	°C Max	PSI (Max)
CSV - 6	1/4"		-35	90	400
CSV - 6 S		1/4"			
CSV - 10	3/8"				
CSV - 10 S		3/8"			
CSV - 12	1/2"				
CSV - 12 S		1/2"			
CSV - 15	5/8"				
CSV - 15 S		5/8"			

Model	DIMENSIONS (MM)						Weight gm
	H1	H2	L1	d	I	D	
CSV-6	69	54	56.5	4.5	28	54	160
CSV-6S	69	54	56.5	4.5	28	54	160
CSV-10	77	59.5	69	4.8	50	54	220
CSV-10S	77	59.5	69	4.8	50	54	210
CSV-12	75	55	80	4.8	50	54	310
CSV-12S	75	55	80	4.8	50	54	290
CSV-15	75	55	80	4.8	50	54	320
CSV-15S	75	55	80	4.8	50	54	290

Valves/ Angle Valve (Receiver Valve)

Application

These receiver valves are designed for installation on commercial refrigerating systems and on civil and industrial air-conditioning systems. They are suitable for all refrigerant fluids except Ammonia.

Construction

The main parts of these valves are made with the following materials :

- hot forged brass as per BS-218
- steel with proper surface protection, for the spindle
- neoprene rubber for the gland
- Engineering Plastics for the cap that covers the spindle

Model	DIMENSIONS (MM)			Weight gm
	H 1	H 2	L 1	
CSV - 6	67	44.5	26	80
CSV - 6 S	67	44.5	26	80
CSV - 10	75	48	31	120
CSV - 10 S	75	48	31	120

Model	Connections	
CAV-76	1/4" Flare	1/4" NPT
CAV-66	1/4" Flare	1/4" Flare
CAV-696	13/48" Flare	13/48" Flare
CAV-99	3/8" Flare	3/8" NPT

Operating Temp		Operating Pressure
°C Min	°C Max	PSI (Max)
-35	90	400

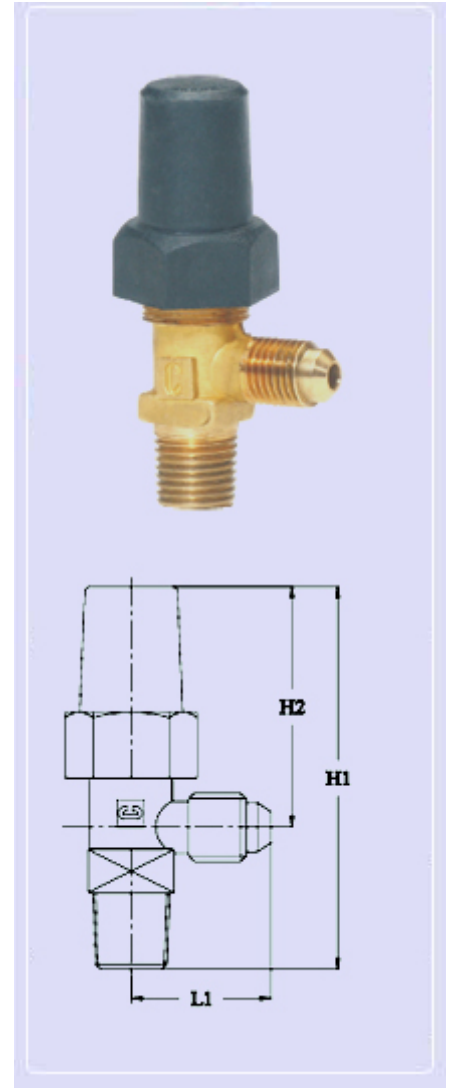

Valves/ Globe Valves

Application

These globe valves are designed for installation on commercial refrigerating systems and on civil and industrial air-conditioning systems.

They are amongst many applications, used to isolate various devices like driers, receivers etc. They have large orifices to keep pressure drops to a minimum. These valves are suitable for all CFC's and HCFC's except Ammonia.

Installation

The brazing of these valves with solder connections should be carried with care using a low melting point filler material.

It is necessary to remove the bonnet assembly with spindle and cap prior to brazing the valve.

Re-assemble the valve only once the valves has cooled completely and reached room temperature.

Model	Size Flare	Size OD	Operating Temp		Operating Pressure
			°C Min	°C Max	PSI (Max)
CGV - 15	5/8"		-35	90	400
CGV - 22	7/8"	1/4"			
CGV - 28	1.1/8"				
CGV - 32	1.3/8"	3/8"			
CGV - 40	1.5/8"				
CGV - 50	2.1/8"	1/2"			

Model	DIMENSIONS (MM)					
	H1	H2	L	Q	A	M
CGV-15	135	27	81	55	97	5/16"BSW
CGV-22	135	27	81	55	97	5/16"BSW
CGV-28	145	32	82	60.5	100	3/8"BSW
CGV-32	160	35.5	96	70	100	3/8"BSW
CGV-40	179	38	101	74	130	3/8"BSW
CGV-50	240	40	132	87	146	5/16"BSW

Valves/ Angle Shut off Valve

Application

These angle shut off valves are designed for installation on commercial refrigerating systems on civil and industrial air-conditioning systems.

They are amongst many applications, used to isolate various devices like driers, receivers etc. They have large orifices to keep pressure drops to a minimum. These valves are suitable for all CFC's and HCFC's except Ammonia. They can be used to Isolate a drier or similar device.

Installation

The brazing of these valves with solder connections should be carried with care using a low melting point filler material.

Model	Size Flare	Operating Temp		Operating Pressure
		°C Min	°C Max	PSI (Max)
CAV - 32	1.3/8"	-35	90	400
CAV - 40	1.5/8"			
CAV - 50	2.1/8"			

Model	DIMENSIONS (MM)				
	H	H1	H2	L	L1
CAV - 32	176	46	75.5	79	41
CAV - 40	176	46	75.5	79	41
CAV - 50	211	58.5	90	96	52

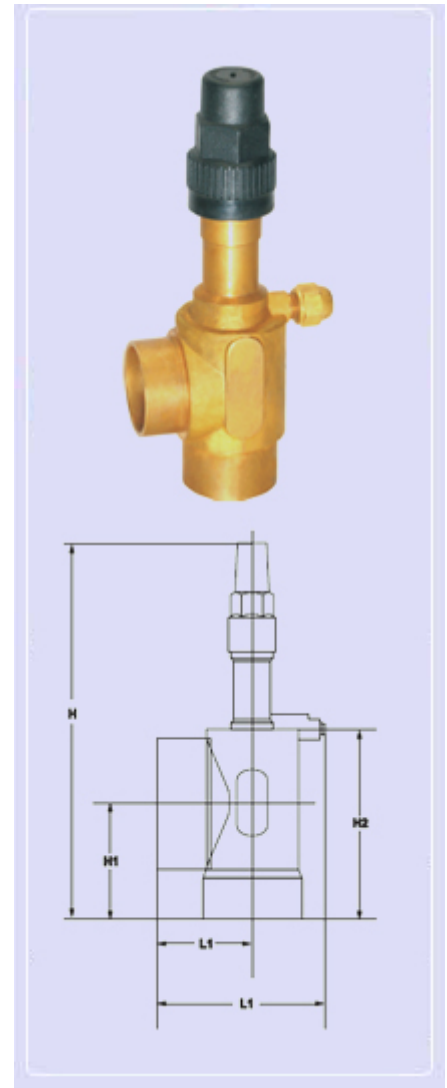

Valves/ Ball Valves

Application

Petroleum, Petrochemical, Chemical, Refrigeration, Air-conditioning and engineering industries. Valves are compatible with Ammonia, CFC, HCFC, Oil, Air, Chemicals, Gas, Acids, Alkalies etc. amongst many other media.

Installation

The three piece design makes the Series C-44 valve the most easily maintainable valve in its type. By removing three body connector bolts and loosening the fourth, the body can be swung away using the fourth bolt as a fulcrum, to carry out any maintenance on the valve. This feature allows the valve to be online and considerably reduces down time.

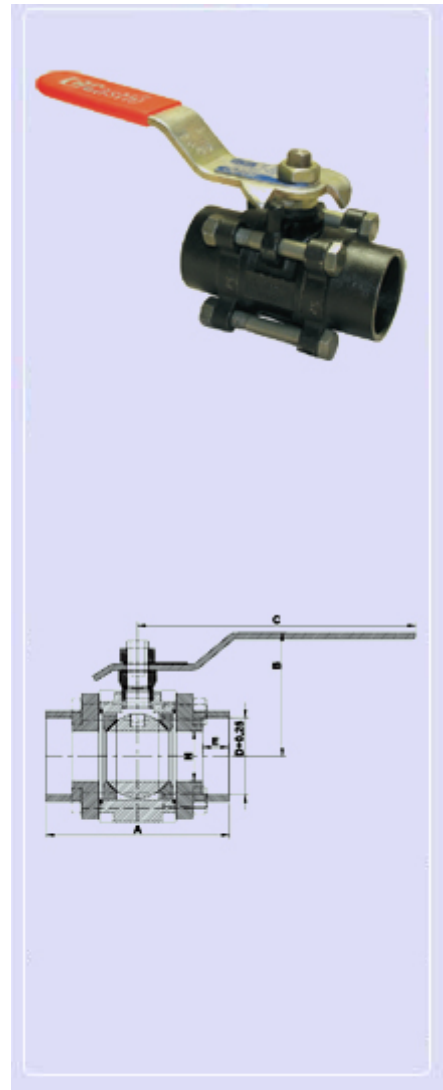

MATERIAL SPECIFICATIONS

Name of Part	Carbon Steel valve	Stainless Steel valve
Body	W.C.B	ASTM A351 Gr.CF 8M
Body Connector		
Ball	AISI 316 or ASTM A351 Gr. CF 8M	
Seat	Virgin PTFE	
Stem	Stainless Steel AISI 304 Virgin PTFE	
Body Seal		
Gland Pancking	35% Carbon filled PTFE	
Stem Seal		

Model	SCREWED / SOCKET-WELD END (IN MM, UNLESS SPECIFIED)							Weight
DN	INCH	A	B	C	D+0.25	E	H	Kg
DN15 (1/2")	1/2" - 5/8"	64	45	122	21.8	9.7	11.2	0.6
DN20 (3/4")	7/8"	75	54	122	27.4	12.7	14.2	1
DN25 (1")	1.1/8"	94	75	148	34.1	12.7	22	1.7
DN32 (1.1/4")	1.3/8"	109	73	182	42.7	12.7	25	2.5
DN40 (1.5")	1.5/8"	118	73	182	49	12.7	32	3.7
DN50 (2")	2.1/8"	127	83	182	61	12.7	38	5
DN65 (2.5")	2.5/8"	145	260	230	77.5	15.9	50	8.5
DN80 (3")	3.1/8"	172	280	230	91	20	63	11.5
DN100 (4")	4.1.8"	185	295	230	117.5	25	72	18
DN125 (5")	5.1/8"	230	295	230	142	25	96	25

Valves/ Angle Shut off Valve

Application

These check valves are designed for installation in liquid, suction and hotgas lines on commercial refrigerating systems and on civil and industrial air-conditioning systems.

Construction

The main parts of the valves are made with the following materials :

- extruded brass as per BS-218
- stainless steel for the spring
- neoprene rubber for outer seal
- PTFE for seat

Installation

The valves can be installed in any section of a refrigerating system, where it is necessary to avoid an inversion of the refrigerating flow.

Before connecting the valve to the pipe it is to make sure that the refrigerating system is clean. Infact the valves with PTFE seats are particularly sensitive to dirt and debris. Furthermore check that the flow direction in the pipe corresponds to the arrow stamped on the body of the valve.

Model	DIMENSIONS (MM)		Weight
	H	D	gm
NRV-6	58.5	25.4	90
NRV-10	61	25.4	100
NRV-12	72	29	150
NRV-15	83	36.5	230

Model	Size Flare	Operating Temp		Operating Pressure
		°C Min	°C Max	PSI (Max)
NRV - 6	1/4"	-35	90	400
NRV - 10	3/8"			
NRV - 12	1/2"			
NRV - 15	5/8"			

