



RELIABLE LUBRICATION



SVM 92 Series

LUBRICATION PUMP

(Pneumatically operated)

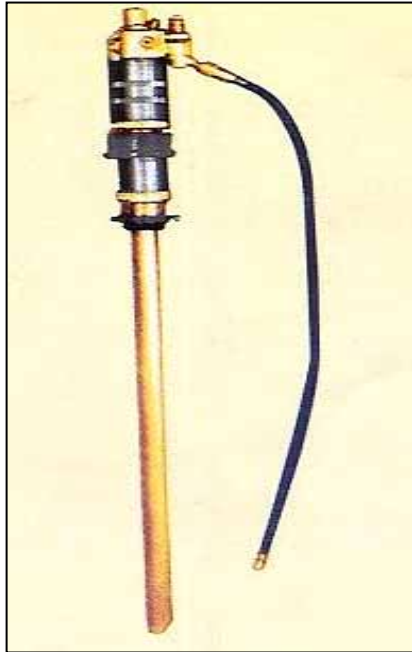

High Pressure Grease Pump:

This model handles any grade of grease, with a working ratio of 50: 1.

A built in air regulator controls the input air to the pump to maintain a constant pump working ratio. This enables safety and correctly rated grease pressure irrespective of the air supply in the pipe line. The pressure up to 4 Kgf/cm², thus making the unit suitable for any specific grease requirements.

The air operated grease pump can be directly mounted on a standard 200 Kg barrel of any oil company, using the follower plate and drum cover. The pump can deliver 300 to 400 gm of grease per minute. The hose reel can be connected to the deliver side of the unit if required. Capable of developing a block pressure of 425 Kgf/cm², the pump has a working ratio 50: 1.



Oil Pump:

This model can be mounted on a standard 200 Kg oil drum. The pump can deliver up to 14 liters of oil per minute at a pressure of 35 Kgf/cm². a compensating vessel at the outlet of the unit reduces fluctuations in the oil output. A bung adaptor is provided to fix the pump to the barrel top and a hose reel can be connected to the delivery side of the pump if required.

PUMP EQUIPMENT

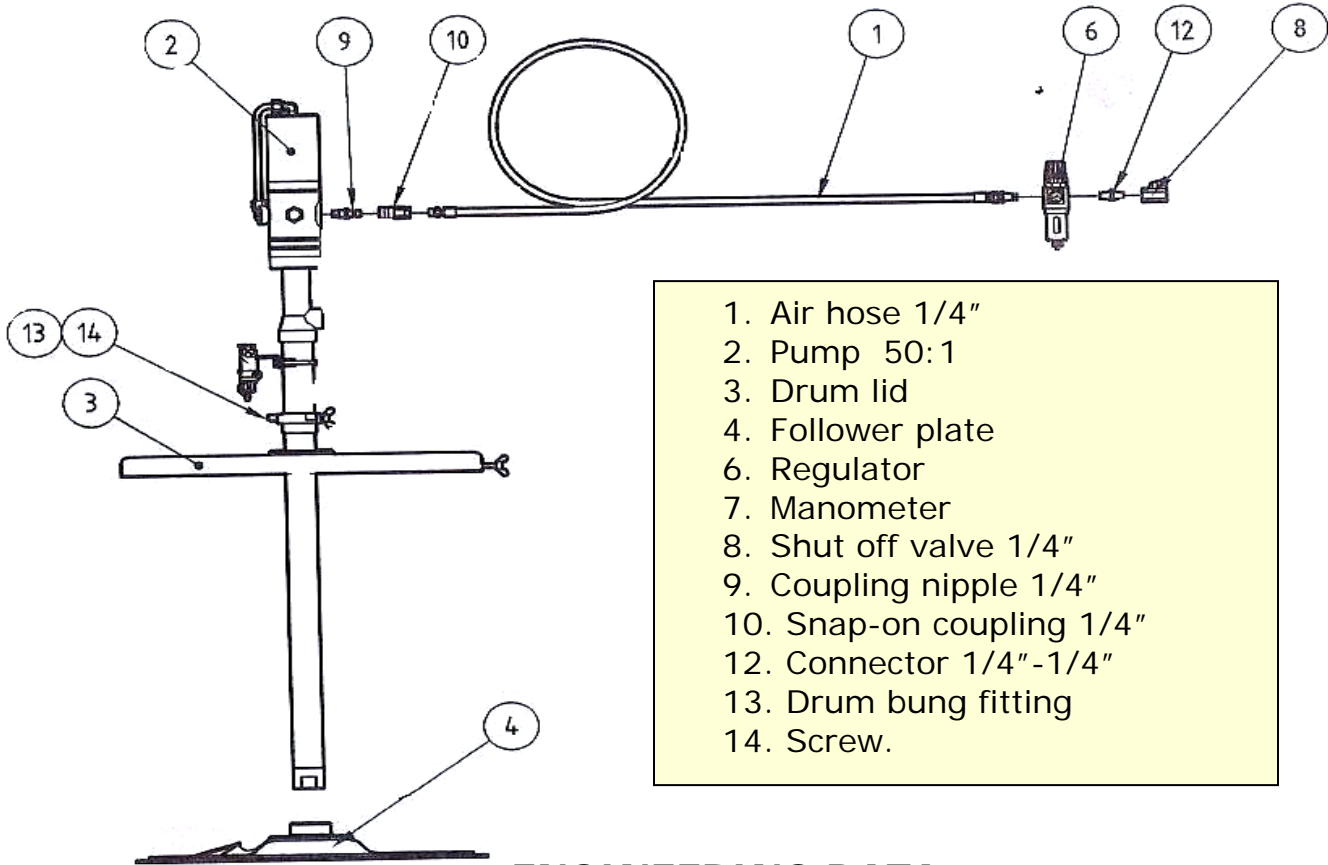

1. Air hose 1/4"
2. Pump 50:1
3. Drum lid
4. Follower plate
6. Regulator
7. Manometer
8. Shut off valve 1/4"
9. Coupling nipple 1/4"
10. Snap-on coupling 1/4"
12. Connector 1/4"-1/4"
13. Drum bung fitting
14. Screw.

ENGINEERING DATA

		Grease pump	Oil Pump
Pneumatically operated			
Pressure Ratio		50:1	3.5:1
Output at 8.5 Kg/cm ² air pressure	lpm	-	14
Output at 8.5 Kg/cm ² air pressure	gms	300 - 400	-
Working pressure range of air	Kg/cm ²	4.5-10.5	4.5-10.5
Recommended working pressure of air	Kg/cm ²	8.5	-
Normal blocked pressure at 8.5 kg/cm ² air pressure	Kg/cm ²	425	29.75
Air Requirements (FAD)	lpm	325	325
Drum Capacity	Litres	200	200

RIKKON LUBE

Reliable Lubrication

S.V.A Rikkon Lube Pvt.Ltd
 203, Nageswara Rao Road, 2 nd Extn, Athipet,
 Chennai- 600 058.

Tel : 91-44-26255880 / 01 Fax : 91-44-26245128

Email: sales@rikkonlube.com Website: www.rikkonlube.com.

Rikkon Lube Warranty

The Rikkon Lube System carries a 1 year warranty on all parts (subject to normal terms and condition of same) in line with completion of our System Warranty registration Card.